



Huawei

AP2050DN-E

Access Point

Datasheet



Product Overview

Huawei AP2050DN-E is the latest-generation gigabit wall plate access point (AP) that complies with 802.11ac Wave 2. It uses an 86 mm x 86 mm plate design and can be easily installed in a standard 86-type junction box. The AP2050DN-E's innovative design boasts built-in antennas, a hidden indicator, and a sliding panel, applicable to environments with densely distributed small rooms, such as hotels, student dormitories, hospitals, and offices. It provides enhanced service support capabilities and features high security, simple network deployment, automatic AC discovery and configuration, and real-time management and maintenance. The AP2050DN-E can connect to wireless terminals through wireless connections or to wired terminals using wired cables. This makes it the ideal choice of customers to construct indoor distributed networks.



AP2050DN-E

- Compliance with 802.11ac Wave 2, MU-MIMO (2SU-2MU), delivering services simultaneously on 2.4G and 5G radios (400 Mbit/s at 2.4 GHz, 867 Mbit/s at 5 GHz, and 1.267 Gbit/s for the device)
- One GE uplink port, four GE downlink ports, and two RJ45 pass-through phone ports (compatible with RJ11)
- Built-in Bluetooth, working with eSight to implement Bluetooth device location
- PoE OUT, supplying power for STAs such as IP phones
- Various installation modes for easy deployment, including plate-mounting and desk-mounting
- USB port for storage and external power supply
- Supports cloud-based management and enables Huawei Agile Controller-Cloud Manager to manage and operate APs and services on the APs, reducing network O&M costs.

Feature Description

Cloud-based management

- Huawei Cloud Managed Network (CMN) Solution consists of the cloud management platform and a full range of cloud managed network devices. The cloud management platform provides various functions including management of APs, tenants, applications, and licenses, network planning and optimization, device monitoring, network service configuration, and value-added services.

1-meter Bluetooth location

- The AP2050DN-E supports built-in Bluetooth. In compliance with BLE4.1, the AP2050DN-E can work with eSight to achieve precise Bluetooth location.

PoE OUT power supply

- The AP2050DN-E supports PoE OUT and can supply power to STAs such as IP phones (providing that the AP uses 802.3at or DC power supply).

MU-MIMO

- The AP2050DN-E supports MU-MIMO and a maximum of two spatial streams, allowing the AP to send data to two STAs simultaneously. 802.11ac is entering the second phase.

802.11ac GE access

- Huawei AP uses the latest-generation 802.11ac chip with the highest performance and strongest coverage capability. It supports the 80-MHz bandwidth mode. Frequency bandwidth increase brings extended channels and more sub-carriers for data transmission, and a 2.16 times higher rate. With 2x2 MIMO support, the AP makes a major leap in Wi-Fi access from 100M to GE.

High-speed, reliable wireless access

• Air port performance optimization

- In high-density scenarios where many users access the network, increased number of low-rate STAs consumes more resources on the air port, reduces the AP capacity, and lowers user experience. Therefore, Huawei APs will check the signal strength of STAs during access and rejects access from weak-signal STAs. At the same time, the APs monitor the rate of online STAs in real time and forcibly disconnect low-rate STAs so that the STAs can reassociate with APs that have stronger signals. The terminal access control technology can increase air port use efficiency and allow access from more users.

• 5G-prior access

- The APs support both 2.4G and 5G frequency bands. The 5G-prior access function enables an AP to steer STAs to the 5 GHz frequency band first, which reduces load and interference on the 2.4 GHz frequency band, improving user experience.

• Load balancing between APs

- After the load balancing function is enabled, the AC distributes users evenly to APs based on user quantity and traffic volume. Traffic load is therefore balanced among APs to ensure stable AP performance.

• Smart roaming

- The smart roaming technology is based on the 802.11k and 802.11v technologies and allows terminals to connect to APs with stronger signals, improving user experience and the overall performance of the wireless network.

Wired and wireless security guarantee

- In terms of data security, Huawei APs converge wired and wireless security guarantee to achieve comprehensive security protection

• Authentication and encryption for wireless access

- The APs support WEP, WPA/WPA2-PSK, WPA/WPA2-802.1x, and WAPI authentication/encryption modes to ensure security of the wireless network. The authentication mechanism is used to authenticate user identities so that only authorized users can access network resources. The encryption mechanism is used to encrypt data transmitted over wireless links to ensure that the data can only be received and parsed by expected users.

- Analysis on non-Wi-Fi interference sources
 - Huawei APs can analyze the spectrum of non-Wi-Fi interference sources and identify them, including baby monitors, Bluetooth devices, digital cordless phones (at 2.4 GHz frequency band only), wireless audio transmitters (at both the 2.4 GHz and 5 GHz frequency bands), wireless game controllers, and microwave ovens. Coupled with Huawei eSight, the precise locations of the interference sources can be detected, and the spectrum of them displayed, enabling the administrator to remove the interference in a timely manner.
- Rogue device monitoring
 - Huawei APs support WIDS/WIPS, and can monitor, identify, defend, counter, and perform refined management on the rogue devices, to provide security guarantees for air interface environment and wireless data transmission.

Automatic radio calibration

- Automatic radio calibration allows an AP to collect signal strength and channel parameters of surrounding APs and generate AP topology according to the collected data. Based on interference from authorized APs, rogue APs, and non-Wi-Fi interference sources, each AP automatically adjusts its transmit power and working channel to make the network operate at the optimal performance. In this way, network reliability and user experience are improved.

Basic Specifications..... //

Hardware specifications

	Item	Description
Physical specifications	Dimensions (W x D x H)	140 mm x 86 mm x 36 mm
	Weight	0.26 kg
	Network ports	Uplink: 1 x GE Downlink: 4 x GE 2 x Pass-through RJ45 port 1 x USB port
	Bluetooth	BLE4.1
Power specifications	Power input	PoE power supply: -48 V DC (in compliance with IEEE 802.3af/at) Power adapter: 48 V \pm 5%
	Maximum power consumption	11.5 W NOTE: The actual maximum power consumption depends on local laws and regulations.

	Item	Description	
Environmental specifications	Operating temperature	0°C to +40°C	
	Storage temperature	-40°C to +70°C	
	Operating humidity	5% to 95% (non-condensing)	
	Altitude	-60 m to +5,000 m	
	Atmospheric pressure	53 kPa to 106 kPa	
Radio specifications	Antenna type	Built-in antennas	
	Antenna gain	4 dBi (2.4 GHz); 5 dBi (5 GHz)	
	Maximum number of users	≤ 256	
	Maximum transmit power	2.4G: 21 dBm(combined power) 5G: 20 dBm(combined power) NOTE: The actual transmit power depends on local laws and regulations.	
	Power increment	1 dBm	
	Receiver sensitivity		2.4 GHz 802.11b: -97dBm @ 1 Mbit/s; -91dBm @ 11 Mbit/s
			2.4 GHz 802.11g : -93dBm @ 6 Mbit/s; -78dBm @ 54 Mbit/s
			2.4 GHz 802.11n (HT20): -93 dBm @ MCS0; -72dBm @ MCS15
			2.4 GHz 802.11n(HT40): -90 dBm @ MCS0; -71 dBm @ MCS15
			5 GHz 802.11a: -93 dBm @ 6 Mbit/s; -77dBm @ 54 Mbit/s
			5 GHz 802.11n (HT20): -92 dBm @ MCS0; -72 dBm @ MCS15
			5 GHz 802.11n (HT40): -89 dBm @ MCS0; -70dBm @ MCS15
			5 GHz 802.11ac (VHT20): -92 dBm @ MCS0NSS1; -71 dBm @ MCS8NSS2
			5 GHz 802.11ac (VHT40): -90 dBm @ MCS0NSS1; -63 dBm @ MCS9NSS2
			5 GHz 802.11ac (VHT80): -86 dBm @ MCS0NSS1; -60 dBm @ MCS9NSS2

Software specifications

Item	Description
WLAN features	<ul style="list-style-type: none">• Compliance with IEEE 802.11a/b/g/n/ac• Maximum rate: 1.267 Gbit/s• Maximum Ratio Combining (MRC)• Space Time Block Code(STBC)• Beamforming• Low Density Parity Check(LDPC)Maximum Likelihood Detection (MLD)• Data unit aggregation, including A-MPDU (Tx/Rx) and A-MSDU (Rx only)• 802.11 Dynamic Frequency Selection (DFS)• Short Guard Interval (GI) in 20 MHz, 40 MHz, and 80 MHz modes• Priority mapping and packet scheduling based on a Wi-Fi Multimedia (WMM) profile to implement priority-based data processing and forwarding• Automatic and manual rate adjustment (the rate is adjusted automatically by default)• WLAN channel management and channel rate adjustment• Automatic channel scanning and interference avoidance• Service Set Identifier (SSID) hiding, support for SSIDs in Chinese• Signal Sustain Technology (SST)• Unscheduled Automatic Power Save Delivery (U-APSD)• Control and Provisioning of Wireless Access Points (CAPWAP)• Automatic access• Hotspot2.0• 802.11k and 802.11v smart roaming• Extended Service Set (ESS) in Fit AP mode• Multi-user CAC

Item	Description
Network features	<ul style="list-style-type: none">• Compliance with IEEE 802.3u• Auto-negotiation of the rate and duplex mode; automatic switchover between the Media Dependent Interface (MDI) and Media Dependent Interface Crossover (MDI-X)• SSID-based VLAN assignment• 4,094 VLAN IDs (1 to 4,094) and a maximum of 8 virtual APs (VAPs) for each radio• AP control channel in tagged and untagged mixed mode• DHCP client, obtaining IP addresses through DHCP• Tunnel forwarding and direct forwarding• STA isolation in the same VLAN• Multicast Domain Name Service (mDNS) gateway protocol: supports AirPlay and AirPrint service sharing between users of different VLANs• Access control lists (ACLs)• Link Layer Discovery Protocol (LLDP)• Service holding upon CAPWAP link disconnection• Unified authentication on the AC• AC dual-link backup• Soft GRE• Network Address Translation(NAT)• IPv6
QoS features	<ul style="list-style-type: none">• Priority mapping and packet scheduling based on a WMM profile to implement priority-based data processing and forwarding• WMM parameter management for each radio• WMM power saving• Priority mapping for upstream packets and flow-based mapping for downstream packets• Queue mapping and scheduling• User-based bandwidth limiting• Adaptive bandwidth management (the system dynamically adjusts bandwidth based on the number of users and radio environment to improve user experience)• Airtime scheduling• Support for Microsoft Lync APIs and high voice call quality through Lync API identification and scheduling

Item	Description
Security features	<ul style="list-style-type: none"> • Open system authentication • WEP authentication/encryption • WPA/WPA2-PSK authentication and encryption • WPA/WPA2-802.1x authentication and encryption • WPA-WPA2 authentication • WAPI authentication and encryption • WIDS including rogue AP and STA detection, attack detection, STA/AP blacklist and whitelist • 802.1x authentication, MAC address authentication, and Portal authentication • 802.11w Protected Management Frames (PMFs) • DHCP Snooping • Dynamic ARP Inspection • IP Source Guard
Maintenance features	<ul style="list-style-type: none"> • Unified management and maintenance on the AC • Plug-and-Play (PnP): automatic ally going online and loading configurations • Batch upgrade • Local AP management through the serial port or using Telnet • STelnet using Secure Shell (SSH) v2 • Secure File Transfer Protocol (SFTP) using SSH v2 • Real-time configuration monitoring and fast fault location using the NMS • System status alarm • Web local AP management through HTTP or HTTPS in Fat AP mode • Simple Network Management Protocol (SNMP) v1/v2/v3 in Fat AP mode • Network Time Protocol (NTP) in Fat AP mode
BYOD	<ul style="list-style-type: none"> • Identifies the device type according to the Organizationally Unique Identifier (OUI) in the MAC address. • Identifies the device type according to the User Agent (UA) information in an HTTP packet • Identifies the device type according to DHCP options. • The RADIUS server delivers packet forwarding, security, and QoS policies according to the device type carried in the RADIUS authentication and accounting packets.
Location service	<ul style="list-style-type: none"> • Locates tags manufactured by AeroScout or Ekahau • Locates Wi-Fi terminals. • Works with eSight to locate rogue devices • Bluetooth location
Spectrum analysis	<ul style="list-style-type: none"> • Identifies interference sources such as baby monitors, Bluetooth devices, digital cordless phones (at 2.4 GHz frequency band only), wireless audio transmitters (at both the 2.4 GHz and 5 GHz frequency bands), wireless game controllers, and microwave ovens. • Works with Huawei eSight to locate and perform spectrum analysis on interference sources.

Standards compliance

Item	Description
Safety standards	UL 60950-1 IEC 60950-1 EN 60950-1 GB 4943
Radio standards	ETSI EN 300 328 ETSI EN 301 893 RSS-210 AS/NZS 4268
EMC standards	EN 301 489-1 EN 301 489-17 ETSI EN 60601-1-2 ICES-003 YD/T 1312.2-2004 ITU k.21 GB 9254 GB 17625.1 EN 55022 EN 55024 CISPR 22 CISPR 24 IEC61000-4-6 IEC61000-4-2
IEEE standards	IEEE 802.11a/b/g IEEE 802.11n IEEE 802.11ac IEEE 802.11h IEEE 802.11d IEEE 802.11e IEEE 802.11k IEEE 802.11u IEEE 802.11v IEEE 802.11w
Security standards	802.11i, Wi-Fi Protected Access 2(WPA2), WPA 802.1x Advanced Encryption Standards (AES), Temporal Key Integrity Protocol (TKIP), and EAP Type (s)
Environmental standards	ETSI 300 019-2-1 ETSI 300 019-2-2 ETSI 300 019-2-3 ETSI 300 019-1-1 ETSI 300 019-1-2 ETSI 300 019-1-3
EMF	CENELEC EN 62311 CENELEC EN 50385 RSS-102
RoHS	Directive 2002/95/EC & 2011/65/EU
Reach	Regulation 1907/2006/EC
WEEE	Directive 2002/96/EC & 2012/19/EU

AP2050DN-E Antenna Pattern Plots

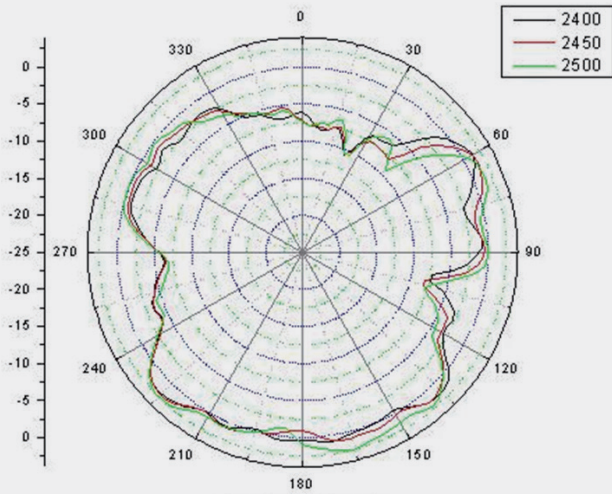

2.4G (PHI=0)

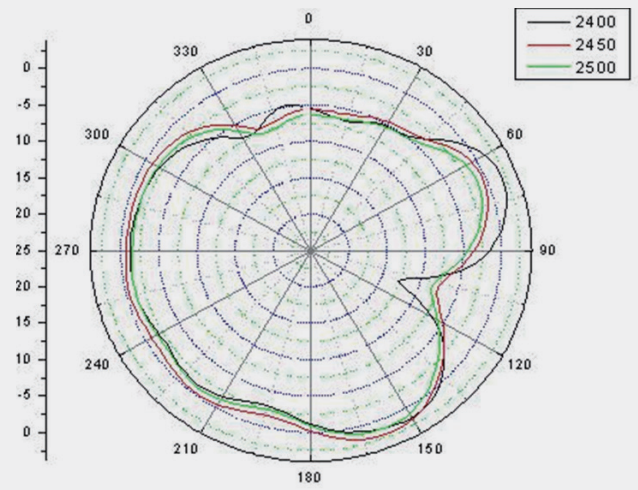

2.4G (PHI=90)

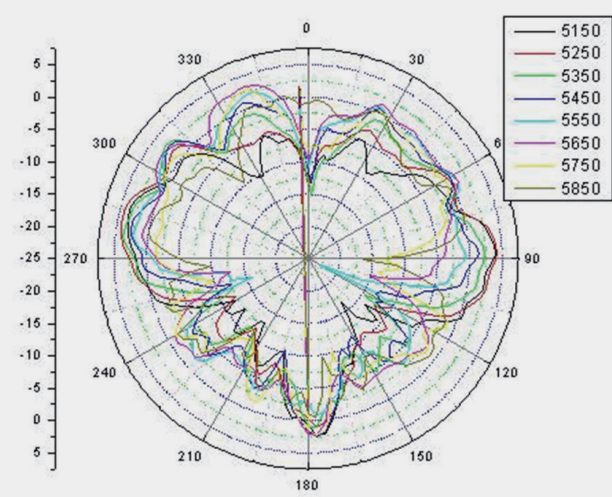

5G (PHI=0)

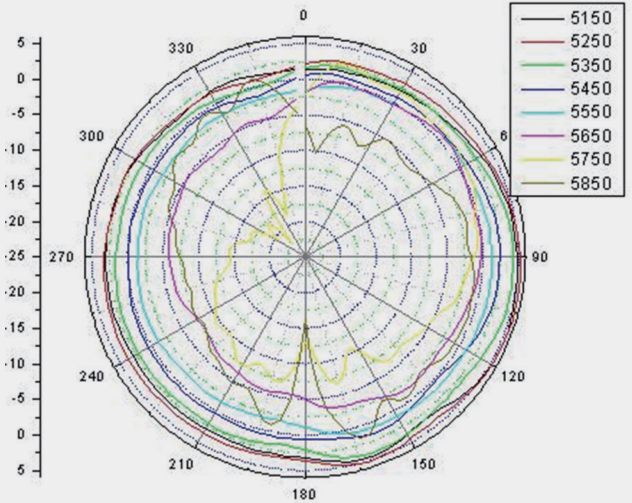

5G (PHI=90)

Professional Service and Support

Huawei WLAN planning tools deliver expert network design and optimization services using the most professional simulation platform in the industry. Backed by fifteen years of continuous investment in wireless technologies, extensive network planning and optimization experience, and rich expert resources, Huawei helps customers:

- Design, deploy, and operate a high-performance network that is reliable and secure.
- Maximize return on investment and reduce operating expenses.

More Information

For more information, please visit <http://e.huawei.com/en/> or contact your local Huawei office.



Enterprise Services



Product Overview

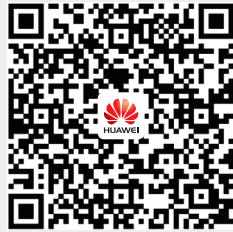



Marketing Documentation

Copyright © Huawei Technologies Co., Ltd. 2016. All rights reserved.

No part of this document may be reproduced or transmitted in any form or by any means without prior written consent of Huawei Technologies Co., Ltd.

Trademark Notice

 HUAWEI, and  are trademarks or registered trademarks of Huawei Technologies Co., Ltd. Other trademarks, product, service and company names mentioned are the property of their respective owners.

General Disclaimer

The information in this document may contain predictive statements including, without limitation, statements regarding the future financial and operating results, future product portfolio, new technology, etc. There are a number of factors that could cause actual results and developments to differ materially from those expressed or implied in the predictive statements. Therefore, such information is provided for reference purpose only and constitutes neither an offer nor an acceptance. Huawei may change the information at any time without notice.

HUAWEI TECHNOLOGIES CO.,LTD.
Huawei Industrial Base
Bantian Longgang
Shenzhen 518129,P.R.China
Tel: +86 755 28780808

www.huawei.com